

# Line Interface

FT634a TRC



**FunkTronic**  
Kompetent für Elektroniksysteme

# Contents

	Page
Technical Data	2
General Features	3
Channel Remote Switching	3
Transmitter control	4
Functions of the LEDs	4
Examples	4
Jumper	6
Block diagram FT634a (C, CL, TRC)	7
Block diagram DSP	8
Pinout	9
RS232-connecting cable	11
Service program/Adjustment	11
Programming	13
Tone table	17
General Safety Instructions	18
Terms and abbreviations	19

## Technical Data

Voltage of operation	+12V DC +/-30%
Current demand	ca. 100 mA
Fuse	1 A, self-resetting
Weight	ca. 525 g
Dimensions W x H x D	104 x 44 x 175 mm
Frequency of pilot tone	ex factory setting: 3300 Hz
Pilot tone decoder	+/- 0,8 % (+/- 26 Hz)
Response time	< 20 ms
Release time	< 40 ms
min. pilot tone level at measuring (monitor.)point	75 mV
Notchfilter pilot tone suppression	> 50 dB

### **2- resp. 4-wire**

Input level 2-wire	-10 dBm nominally, 250 mV
Adjustment range 2-wire	-41 dBm to -1 dBm, 7 mV to 700 mV
Input level 4-wire	-9 dBm nominally, 275 mV
Adjustment range 4-wire	-40 dBm to +1 dBm, 8 mV to 850 mV
Input impedance	2-wire Zr or 600 Ohm, 4-wire 600 Ohm
Output level 2-wire	-10 dBm, 250 mV (or: -19 dBm, 90 mV)
Pilot tone 2-wire	-12 dBm, 200 mV
Output level 4-wire	-14 dBm, 150 mV (or: -5 dBm, 450 mV)
Pilot tone 4-wire	-16 dBm, 125 mV
Output impedance 2-wire	Zr or 600 Ohm
Output impedance 4-wire	600 Ohm

### **Interface radio device resp. desk top control**

Input level	+ 3 dBm nominally, 1100 mV
Adjustment range	- 24 to + 6 dBm, 50 mV to 1550 mV
Input impedance	600 Ohm
Output level	- 17 dBm ex factory setting, 100 mV
Adjustment range	- 30 to + 8 dBm, 25 mV to 2000 mV
Output impedance	600 Ohm

# General Features

The new line interface FT634a is completely constructed in SMD-technology. The connections are pin-compatible with the former version, but instead of male connectors there are female connectors. The line interface is used to remotely operate a two-way radio by a 2- or 4-wire connection. It is possible to bridge very long distances depending on the cable attenuation.

## Features

- 2- or 4-wire connection (selectable by jumper)
- Impedance 600 Ohm or Zr (selectable by jumper) (Zr only for 2-wire)
- Connector radio device --> AF-in/output and PTT-out
- Serial interface RS232 to adjust and program
- All levels adjustable with RS232
- All AF-in/outputs galvanically separated (transformer)

## Version FT634a TRC

In version FT634aTRC the pilot-tone encoder is replaced by a TRC encoder. Hence, no pilot-tones can be decoded but only TRC tones.

The following parts of the TRC protocol are supported:

- Guard Tones with the frequencies 2100Hz, 2175Hz und 2325Hz
- a following Function Tone with frequencies from 650Hz to 2050Hz and the following functions:
  - PTT/ channel 1 - 8
  - repeater on / off (optional)

Ex factory, the FT634a TRC is programmed with common standard values. Only the desired Guard Tone frequency must be programmed in register 040, digit 1.

The FT634a TRC is available in two different housings:

- black flange aluminum housing



- 19 inch plug-in unit  
(picture of old 7TE version)  
Attention: Since 2024 the 19" units are 10TE.  
Please plan your designs accordingly.

# Channel Remote Switching

Channel remote switching is achieved via the transmission of different Function Tones.

## Transmitter control

The transmitter control is activated as soon as the AC-line receives and decodes the pilot tone. Then the PTT-output is switched by a potential-free relay. The PTT-output can also be controlled by DC- or AF-decoding (register 053/1).

## Functions of the LEDs

The **green LED** is on when the TRC sequence is decoded by the AC-line or a DC potential is applied or AF is decoded depending on the configuration. The green LED blinks when there is a decoding but the switching of the transmitter relay is suppressed.

The **yellow LED** is on when the pilot tone was activated or DC applied to the line or the AF connected to the line. The yellow LED blinks when the activation of one of the afore-mentioned functions is suppressed.

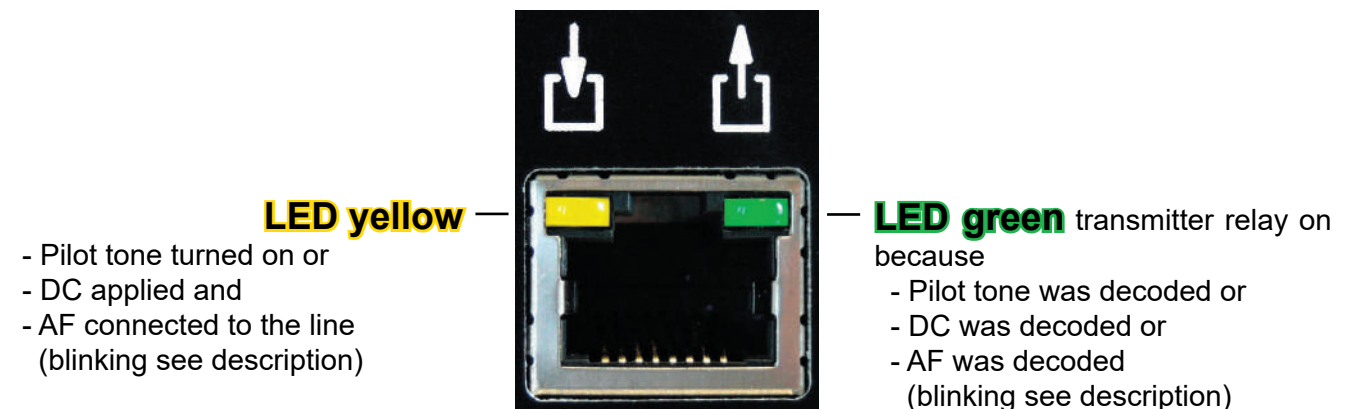

## Examples

### Example 1: 2- or 4-wire remote control via private lines

Major 4a or 5a

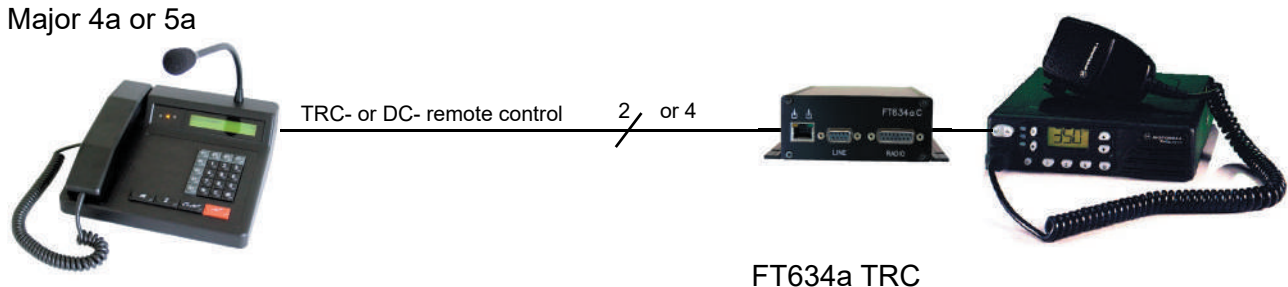

**Example 2:** Parallel circuit of several operation terminals

Major 5a



Major 4a



FT624



FT634a TRC



The Major needs to be equipped with a notch filter for the Guard Tone frequency.

---

**Beispiel 3:** 2-wire remote control via leased lines.

Major 4a, 5a or 6



LIM AC TRC(only 2-wire)



FT634a TRC







# Jumper

Different configurations can be adjusted with the internal jumpers. For example you can choose between 2- or 4-wire connections. The functions of the different jumpers are printed directly onto the circuit board.

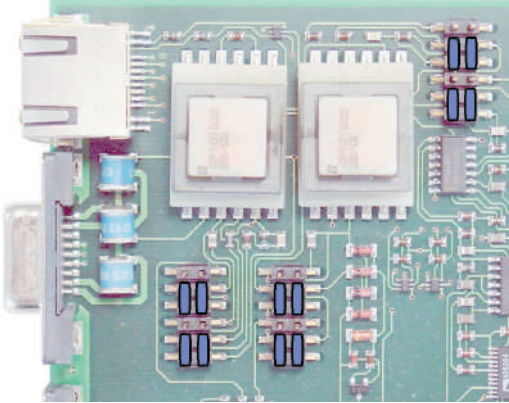
## Jumper setting normal, 2D, Zr, AC (ex factory)



- 2D = 2 wire
- 4D = 4 wire
- Zr = complex impedance
- 600 = real impedance 600 Ohm
- AC = remote control by AC voltage
- DC = remote control by DC voltage
-  = jumper

## Jumper setting 2D, Zr, DC

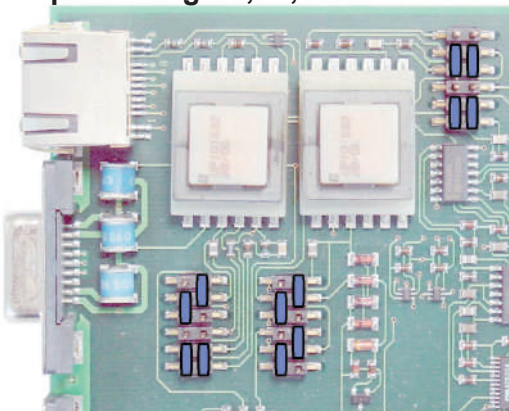

## Jumper setting 2D, 600 Ohm, AC

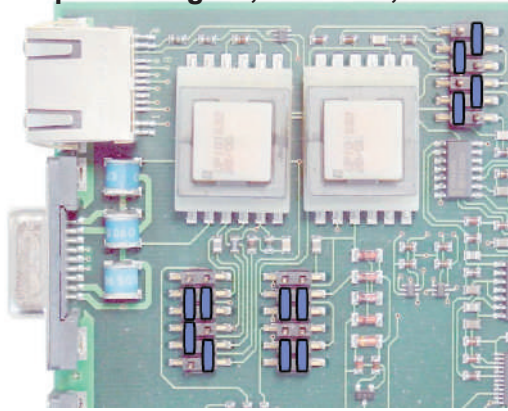

## Jumper setting 2D, 600 Ohm, DC

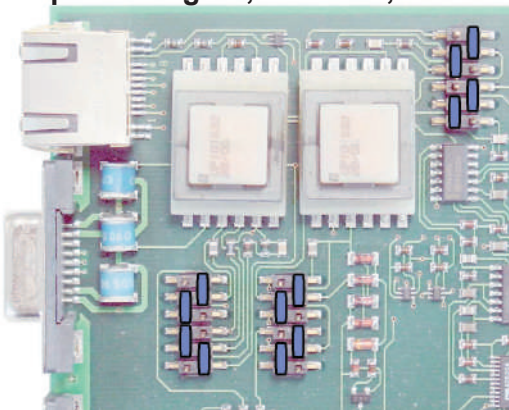

## Jumper setting 4D, 600 Ohm, DC

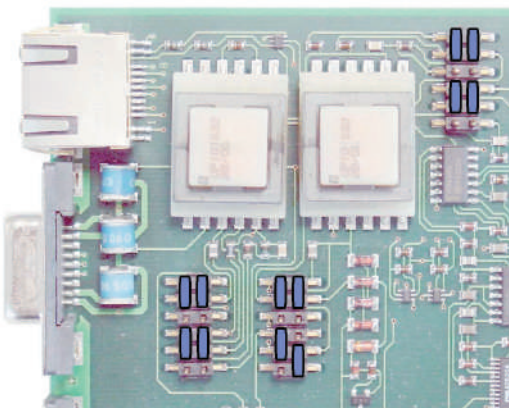

## Jumper setting 4D, 600 Ohm, AC

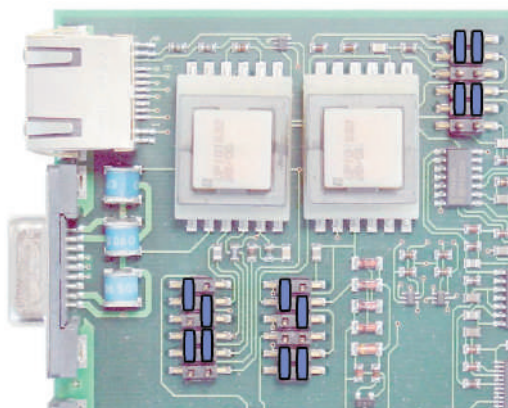

# Block diagram FT634a (C, CL, TRC)

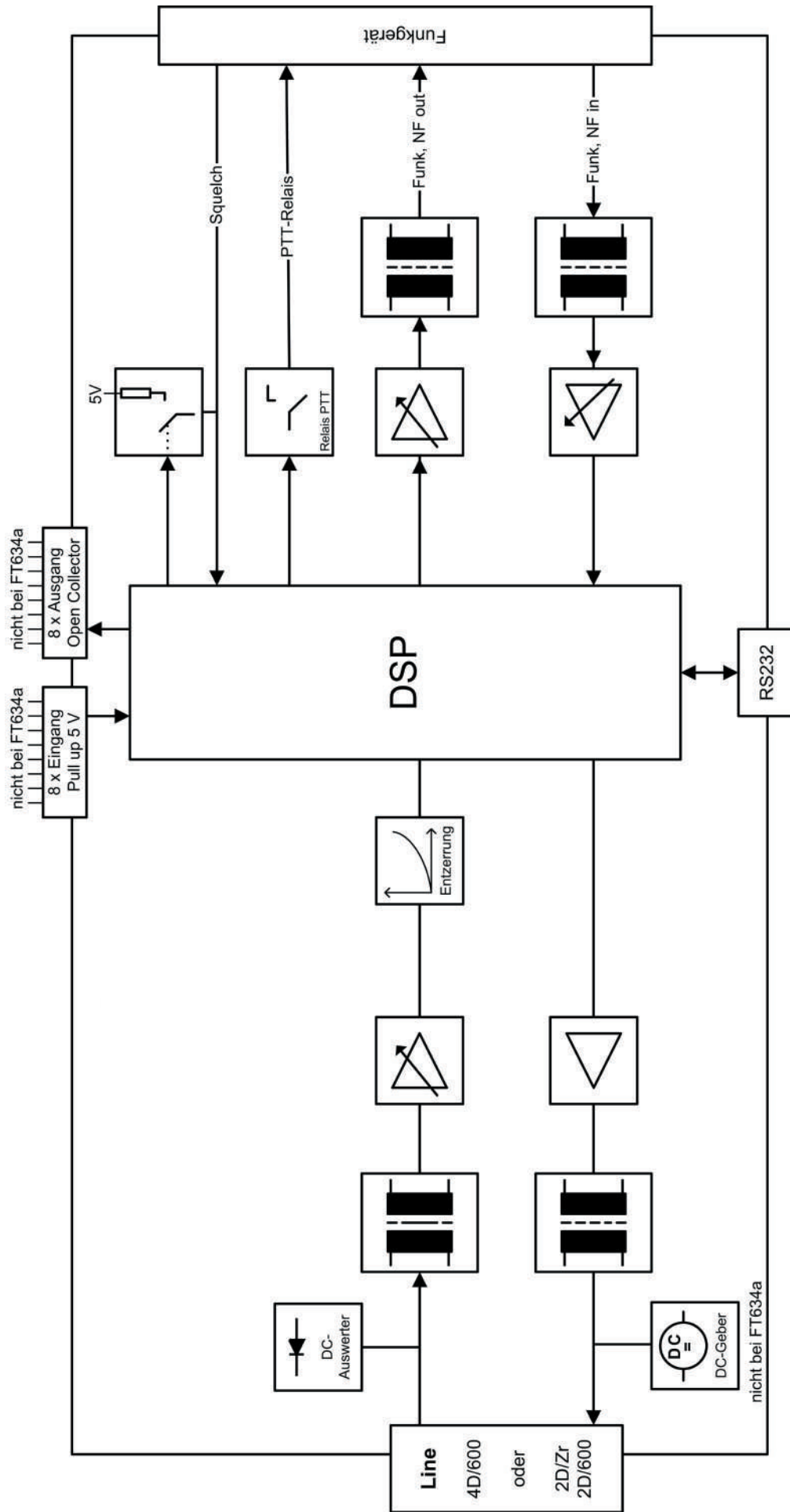

# Block diagram DSP

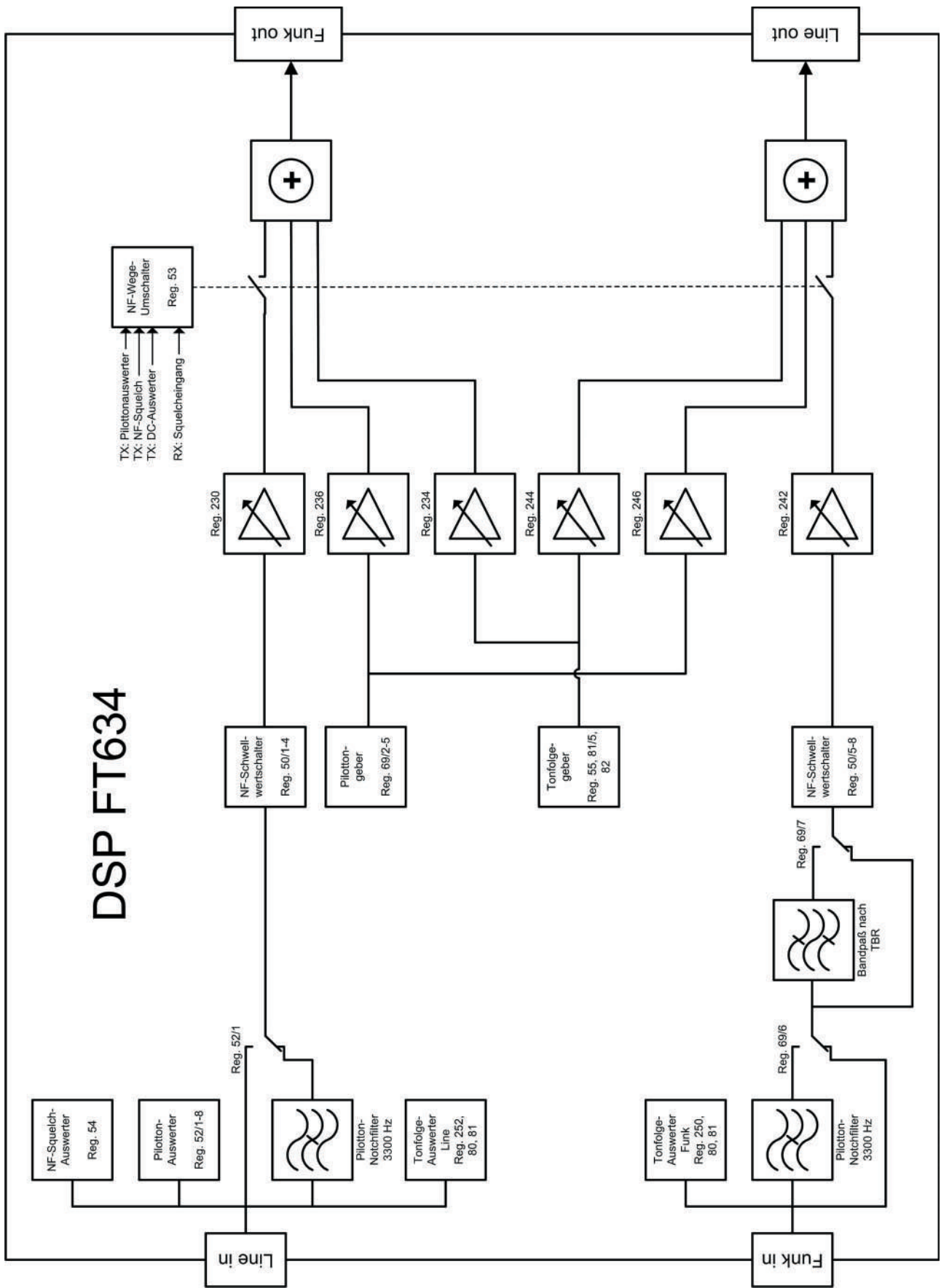



# Pinout

The pinout is the same for all types of the FT634a.



## 8-pin Western jack "RS232"

**LED yellow**

- pilot tone on or
- DC on and
- AF connected to line  
(blinking see description)

**LED green:** transmitter relay on, because

- pilot tone decoded or
- DC decoded or
- AF decoded  
(blinking see description)

I/O 12 (Aus/Eingang)	8
I/O 11 (Aus/Eingang)	7
I/O 10 (Aus/Eingang)	6
I/O 09 (Aus/Eingang)	5
I/O 08 (Aus/Eingang)	4
GND (Aus/Eingang)	3
RS232 RxD (Eingang)	2
RS232 TxD (Ausgang)	1

## 9-pin Sub-D jack "LINE"

I/O: Line, 2D, 4D out

frei

I/O: GND

frei

I/O: Line, 2D, 4D in

6 OUT: Line, 4D out

7 I/O: I/O 13 (Pull-up 5V)

8 I/O: I/O 4 (o.C.)

9 IN: Line, 4D in

## 15-pin Sub-D jack "RADIO"

IN : + 12 V	1		9	IN: + 12 V
OUT: PTT-Relay	2		10	IN: Squelch
OUT: PTT-Relay	3		11	IN: radio, AF in
OUT: radio, AF out	4		12	IN: radio, AF in
OUT: radio, AF out	5		13	I/O: I/O 2 (o.C.)
I/O: I/O 0 (o.C.)	6		14	I/O: I/O 3 (o.C.)
I/O: I/O 1 (o.C.)	7		15	I/O: GND
I/O: GND	8			

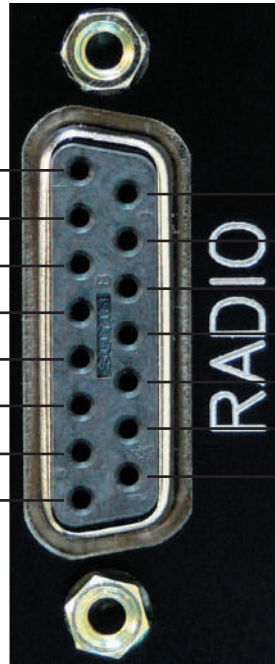

## 64-pin bus connector, 19 inch version

Pin	A	C
1	<b>IN : + 12 Volt</b>	<b>IN: + 12 Volt</b>
2	IN : Analog 1 (0-7V)	IN: Analog 2 (0-7V)
3	I/O: I/O 08 (Pull-up 5V)	
4	I/O: I/O 09 (Pull-up 5V)	<b>IN : Line, 4D in</b>
5	I/O: I/O 10 (Pull-up 5V)	<b>OUT: Line, 4D out</b>
6	I/O: I/O 11 (Pull-up 5V)	<b>I/O: Line, 2D, 4D out</b>
7	I/O: I/O 12 (Pull-up 5V)	<b>I/O: Line, 2D, 4D in</b>
8	I/O: I/O 13 (Pull-up 5V)	OUT: bus, AF RADIO>BUS
9	I/O: I/O 14 (Pull-up 5V)	IN : bus, AF BUS>LINE
10	I/O: I/O 15 (Pull-up 5V)	<b>IN : radio, AF in</b>
11	I/O: I/O 0 (o.C.)	<b>IN : radio, AF in</b>
12	I/O: I/O 1 (o.C.)	
13	I/O: I/O 2 (o.C.)	
14	I/O: I/O 3 (o.C.)	
15	I/O: I/O 4 (o.C.)	<b>OUT: radio, AF out</b>
16	I/O: I/O 5 (o.C.)	<b>OUT: radio, AF out</b>
17	I/O: I/O 6 (o.C.)	I/O: I/O 7 (o.C.)
18	IN : plug-in position config. 1	
19	IN : plug-in position config. 2	
20	IN : plug-in position config. 3	IN : bus, AF BUS>RADIO
21	IN : plug-in position config. 4	I/O: DATA (RS232_UGA)
22	IN : RXD (RS232_ext)	OUT: TXD (RS232_ext)
23	I/O: SDA (I2C)	I/O: SCL (I2C)
24	<b>OUT: PTT-Relay</b>	<b>OUT: PTT-Relay</b>
25		
26	<b>IN : Squelch</b>	
27		
28		
29		
30		
31	OUT: +3,3V	OUT: +5V
32	I/O: GND	I/O: GND

# RS232-connecting cable

Computer equipped with RS232 9-pin jack

RS232 jack on FT634

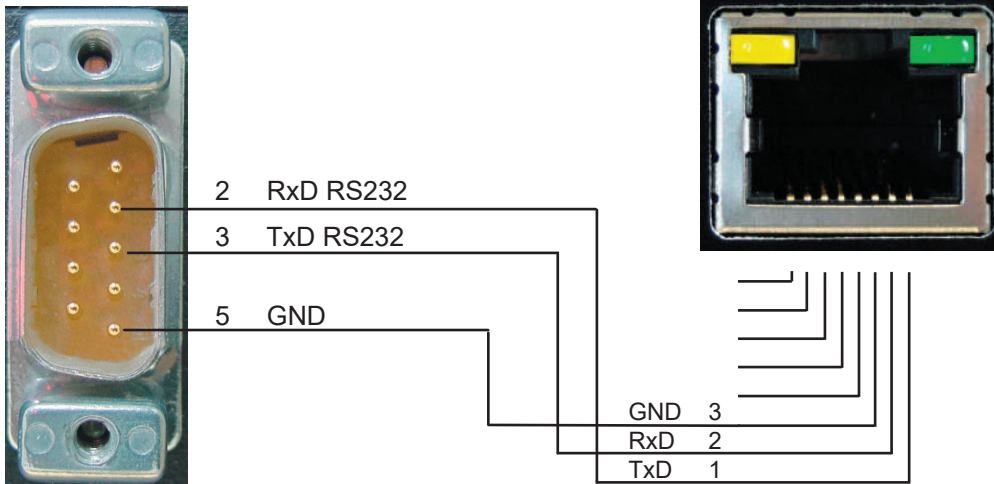

## Service program/Adjustment

The **FT 634aC** has a RS-232 interface with the following specifications  
**9600 Baud, 1 Startbit, 8 Data bits, No Parity, 1 Stop bit,  
neither protocol nor Xon/Xoff**

For communication with Windows e.g. the terminal program "HyperTerminal" can be used. For Linux we recommend the program minicom.

After hitting the key ENTER the terminal program prompts you for input:

```
Online - Monitor FT634a
-----

Software: FT634aTRC
Version : V1.00
SW-date: 17.10.06

Rxxx.....read register xxx
Pxxx yyyyyyy.....program register xxx with yyyyyyy
A.....adjust potentiometer
Tx.....TX-relay on/off (1/0)
Kxx.....switch channel xx (00-99,?)
Ixxxx.....tone generator on with xxxHz
$xxxxx .....transmit tone sequence xxxxx
Q.....reset software
X.....end monitor
```

After hitting the key **A** the monitor prompts you for adjustment with the following screen :

```
Which potentiometer is to be adjusted?

1: input of line - amplification
2: input of line - equalization
3: output to two-way radio
4: input of two-way radio
x: end
```

### The screen for potentiometer 1:

(The actual reading of the internal reference value is shown after changing or blank key.)

```
Adjustment potentiometer 1:
Feed with required level into line-input at 1000Hz.
Adjust ,Line` to 300mV at internal reference value.
Initial value: adjustment potentiometer 1:
Feed with required level into line-input at 1000Hz.
Adjust ,Line` to 300mV at internal reference value.
Initial value: 014 (min:000 max:255) level: 000 mV reference value:
300 mV
Keys:  <+> : +1
        <*> : +10
        <-> : -1
        <_> : -10
        < > : measuring only
        <a> : self-adjustment
        <p> : programming
        <x> : cancel
```

### The screen for potentiometer 2:

```
Adjustment potentiometer 2:
Feed with required level at line-input at 3400Hz.
Adjust ,Line` to 300mV at internal reference value.
Initial value: 057 (min:000 max:255) level: 000 mV required value:
300 mV
Keys:  <+> : +1
        <*> : +10
        <-> : -1
        <_> : -10
        < > : measuring only
        <a> : self-adjustment
        <p> : programming
        <x> : cancel
```

### The screen for potentiometer 3:

```
Adjustment potentiometer 3:
Feed with required level at line-input at 1000Hz.
Adjustment pot 1 and 2 (reference value ,Line` = 300mV).
Adjustment radio-output at required value (required modulation
depth).
Initial value: 015 (min:000 max:255)
Keys:  <+> : +1
        <*> : +10
        <-> : -1
        <_> : -10
        <t> : transmitter on/off
        <p> : programming
        <x> : cancel
```

### The screen for potentiometer 4:

```
Adjustment potentiometer 4:
Feed at radio input with required level at 1000Hz.
Adjust at internal reference value ,Radio` to 300mV.
Initial value: 160 (min:000 max:255) level: 000 mV required value:
300 mV
Keys:  <+> : +1
        <*> : +10
        <-> : -1
        <_> : -10
        < > : measuring only
        <a> : self-adjustment
        <p> : programming
        <x> : cancel
```

Reg.	Default	Description
<b>040</b>	<b>04800540</b>	Parameters for decoding the TRC High Level Guard Tone (HLGT) 1. digit: guard tone frequency 0 = no decoding of TRC 1 = 2100 Hz 2 = 2175 Hz 3 = 2335 Hz 2. digit: tone duration until HLGT is decoded (n * 5 ms) 3. digit: max. duration of the HLGT (n * 20 ms) 4. - 8. digit: min. level (0 - 32767), 00540 = 150 mV *2 = -3 dB, /2 = +3 dB sensitivity
<b>041</b>	<b>06400045</b>	Parameters for decoding the TRC Function Tone (FT) 2. digit: decoding time after end of HLGT (n * 5 ms) 3. digit: min. duration of the FT (n * 5 ms) 4. - 8. digit: min. level (0 - 32767), 00045 = 50 mV *2 = -3 dB, /2 = +3 dB sensitivity
<b>042</b>	<b>32A00006</b>	Parameters for decoding the TRC Low Level Guard Tone (LLGT) 1. digit: amplification factor for LLGT filter 2. digit: decoding duration of LLGT (n * 5 ms) until LLGT = an 3. digit: decoding duration of LLGT (n * 5 ms) until LLGT = aus 4. - 8. digit: min. level (0 - 32767), 0006 = 5 mV *2 = -3 dB, /2 = +3 dB sensitivity
<b>043</b>	<b>19500000</b>	Frequency of the function tone 1.-4. digit: frequency in Hz
<b>046</b>	<b>00111213</b>	Function for Function Tone 0-3 1. + 2. digit: function for tone 0 (2050 Hz) 3. + 4. digit: function for tone 1 (1950 Hz) (channel 1) 5. + 6. digit: function for tone 2 (1850 Hz) (channel 2) 7. + 8. digit: function for tone 3 (1750 Hz) (channel 3)
<b>047</b>	<b>14202115</b>	Funktion for Function Tone 4-7 1. + 2. digit: function für tone 4 (1650 Hz) (channel 4) 3. + 4. digit: function für tone 5 (1550 Hz) (relay off, optional) 5. + 6. digit: function für tone 6 (1450 Hz) (relay on, optional) 7. + 8. digit: function für tone 7 (1350 Hz) (channel 5)
<b>048</b>	<b>16171800</b>	Funktion for Function Tone 8-B 1. + 2. digit: function für tone 8 (1250 Hz) (channel 6) 3. + 4. digit: function für tone 9 (1150 Hz) (channel 7) 5. + 6. digit: function für tone A (1050 Hz) (channel 8) 7. + 8. digit: function für tone B (0950 Hz)
<b>049</b>	<b>00000000</b>	Funktion for Function Tone C-E 1. + 2. digit: function für tone C (0850 Hz) 3. + 4. digit: function für tone D (0750 Hz) 5. + 6. digit: function für tone E (0650 Hz)

### For registers 046 - 049

1. ,3.,5.,7 digit: function: 0 = none, 1 = channel, 2 = relay  
2.,4.,6.,8., digit: channel 1 - 8 (1,2,3,...,8) or relay off/on (0,1)

Reg.	Default	Description
<b>050</b>	03100320	<p>AF-mute level</p> <p>1.+2. digit: ca. nn*0,9mV threshold AF-mute line&gt;radio activation</p> <p>3.+4. digit: ca. nn*0,9mV threshold AF-mute line&gt;radio deactivation</p> <p>5.+6. digit: ca. nn*0,9mV threshold AF-mute line&gt;line activation</p> <p>7.+8. digit: ca. nn*0,9mV threshold AF-mute radio&gt;line deactivation</p>
<b>052</b>	12500128	<p>Guard Tone Filter</p> <p>1. Stelle: Guard Tone filter frequency 0=no filter</p> <p>1=2100Hz</p> <p>2=2175Hz</p> <p>3=2325Hz</p>
<b>053</b>	12211220	<p>TX-configuration</p> <p>1. digit: TX-decoder 0=off, 1=PIL, 2=DC, 3=PIL+DC, 4=AF-squelch</p> <p>2. digit: operating mode:</p> <p>0: 4-wire, low amplification of line (-25...0dBm)</p> <p>1: 4-wire, high amplification of line (-40...-15dBm)</p> <p>2: 2-wire, low amplification of line (-25...0dBm)</p> <p>3: 2-wire, high amplification of line (-40...-15dBm)</p> <p>3. digit: priority</p> <p>0: none</p> <p>1: RX before TX</p> <p>2: TX before RX</p> <p>3: first come, first served...</p> <p>4. digit: AF-directions without RX, without TX</p> <p>5. digit: AF-directions with RX, without TX</p> <p>6. digit: AF-directions without RX, with TX</p> <p>7. digit: AF-directions with RX, with TX</p> <p>4. to 7. digit: 0=RADIO&gt;LINE off, LINE&gt;RADIO off</p> <p>1=RADIO&gt;LINE on , LINE&gt;RADIO off</p> <p>2=RADIO&gt;LINE off, LINE&gt;RADIO on</p> <p>3=RADIO&gt;LINE on , LINE&gt;RADIO on</p> <p>8. digit: line amplification</p> <p>0= auto, amplification low at 4-D, high at 2-D</p> <p>1=amplification low</p> <p>2=amplification high</p> <p>RX meaning SQL-input (056/1), TX means TX-decoder (053/1)</p>
<b>054</b>	02604010	<p>AF-squelch configuration</p> <p>1.-2. digit: n*5ms above threshold, until SQL on</p> <p>3.-4. digit: ca. nn*1,8mV threshold AF on</p> <p>5.-6. digit: n*5ms below threshold, until SQL off</p> <p>7.-8. digit: ca. nn*1,8mV threshold AF off</p>
<b>055</b>	10100000	<p>Advance time register</p> <p>1.+2. digit: nn*10ms advance time</p> <p>3.+4. digit: nn*10ms delay time</p>



- 056** 00051205 Squelch configuration
- 1. digit: squelch input
    - 0: active low, pullup on
    - 1: active high, pullup off
    - 2: free (audio squelch)
    - 3: free (phantom)
    - 4: active low, pullup off
    - 5: active high, pullup on
  - 3.+4. digit: nn\*10ms TX-blocking period after own AF on line, only 2-wire
  - 5.+6. digit: nn\*10ms TX-blocking period after own DC on line, only 2-wire
  - 7.+8. digit: nn\*10ms TX-blocking-period after own pilot tone on line, 2-wire
- 057** 00000000 1. digit: language of online monitor
- 0: German
  - 1: English
  - 2: French
  - 3: Dutch
  - 4: Italian
- 064** 00100000 Channel register
- 2.+3. digit: channel 00-99
- 065** 30100000 Blocking-periods for RX and TX
- 1.+2. digit: nn \* 10 ms before channel switching
  - 3.+4. digit: nn \* 10 ms after channel switching
- 066** 01080000 Channel configuration
- 2. digit: channel output
    - 0: none
    - 1: decimal
    - 2: binary-1
    - 3: binary
    - 4: 2xBCD
  - 3. digit: 0: channel output normal  
1: channel output inverted
  - 4. digit: number of channel bits (0-8)
- 069** 00000100 RX-configuration
- 1. digit: RX-signaling to line
    - 0: TRC
    - 2: DC
    - 3=I/O4
    - 4=PTT at 9pole DSub line connector ST2, Pin8
  - 2.-5. digit: pilot tone frequency in Hz
  - 6. digit: pilot tone filter frequency
    - 0=no filter
    - 1=3300Hz
    - 2=3000Hz
    - 3=2800Hz
    - 4=3320Hz
    - 5=2982Hz
    - 6=3850Hz
  - 7. digit: line filter, 0=off, 1=on (bandpass 300-3400Hz)
- 080** 01810000 Decoder reference 1
- 1.-3. digit: nnn\*5ms max. tone duration 1st tone
  - 4.+5. digit: nn\*5ms min. tone duration all tones

<b>081</b>	<b>01800000</b>	Decoder reference 2 1.-3. digit: nnn*5ms max. tone duration from 2nd tone on 5. digit: tone calling system 0:ZVEI, 1:CCIR, 2:ZVEI2, 3:EEA, 4:ZVEI3
<b>082</b>	<b>07707000</b>	Encoder reference 1.+2. digit: nn * 10ms tone duration 1st tone 3. digit: n * 10ms tone duration all other tones 4.+5. digit: nn * 10ms duration of break
<b>083</b>	<b>10001000</b>	Tone duration single-tone and special tone decoder 1.+2.digit: minimum tone duration single-tone decoding *100ms (für Reg.073/1) 3.+4.digit: maximum tone duration single-tone decoding *100ms 00 = decoding as soon as minimum duration is reached >00= decoding, if tone duration is between min and max 5.+6.digit: minimum tone duration special tone decoding *100ms (for reg.073/3) 7.+8.digit: maximum tone duration special tone decoding *100ms 00 = decoding as soon as minimal duration is reached >00= decoding, if tone duration is between min and max
<b>103</b>	<b>DCBCDCBC</b>	Configuration switching inputs FT634C 1.-4. digit: tone sequence digits 1-4 5.-8. digit: expected acknowledgement
<b>230</b>	<b>00025560</b>	4.-8. digit: multiplier for output level line>radio (0-32768)
<b>234</b>	<b>00008300</b>	4.-8. digit: multiplier for output level tone>radio (0-32768)
<b>236</b>	<b>00000000</b>	4.-8. digit: multiplier for output level pilot>radio (0-32768)
<b>242</b>	<b>00025560</b>	4.-8. digit: multiplier for output level radio>line (0-32768)
<b>244</b>	<b>00008300</b>	4.-8. digit: multiplier for output level tone>line (0-32768)
<b>245</b>	<b>00006400</b>	4.-8. digit: multiplier for output level High Level Guard Tone > Line (0-32768)
<b>246</b>	<b>00006400</b>	4.-8. digit: multiplier for output level Function Tone > Line (0-32768)
<b>247</b>	<b>00006400</b>	4.-8. digit: multiplier for ourput level Low Level Guard Tone > Line (0-32768)
<b>250</b>	<b>00000128</b>	4.-8. digit: min. level for tone decoding of radio (0-32768)
<b>251</b>	<b>00000128</b>	4.-8. digit: min. level for tone decoding of line (0-32768)

## Tone table

Tone table				
Tone	ZVEI 1	CCIR	ZVEI 2	EEA
0	2400 Hz	1981 Hz	2400 Hz	1981 Hz
1	1060 Hz	1124 Hz	1060 Hz	1124 Hz
2	1160 Hz	1197 Hz	1160 Hz	1197 Hz
3	1270 Hz	1275 Hz	1270 Hz	1275 Hz
4	1400 Hz	1358 Hz	1400 Hz	1358 Hz
5	1530 Hz	1446 Hz	1530 Hz	1446 Hz
6	1670 Hz	1540 Hz	1670 Hz	1540 Hz
7	1830 Hz	1640 Hz	1830 Hz	1640 Hz
8	2000 Hz	1747 Hz	2000 Hz	1747 Hz
9	2200 Hz	1860 Hz	2200 Hz	1860 Hz
A	2800 Hz	2400 Hz	886 Hz	1055 Hz
B	810 Hz	930 Hz	810 Hz	930 Hz
C	970 Hz	2247 Hz	740 Hz	2247 Hz
D	886 Hz	991 Hz	680 Hz	991 Hz
E	2600 Hz	2110 Hz	970 Hz	2110 Hz
duration	ZVEI 1	CCIR	ZVEI 2	EEA
min.	52.5 ms	75 ms	52.5 ms	30 ms
typ.	70 ms	100 ms	70 ms	40 ms
max.	87.5 ms	125 ms	87.5 ms	50 ms

# **General Safety Instructions**

Please read the operating instructions carefully before installation and setup.

The relevant regulations must be complied to when working with 230V line voltage, two-wire-lines, four-wire-lines and ISDN-lines. It is also very important to comply to the regulations and safety instructions of working with radio installations.

## **Please comply to the following safety rules:**

- All components may only be mounted and maintained when power is off.
- The modules may only be activated if they are built in a housing and are scoop-proof.
- Devices which are operated with external voltage - especially mains voltage - may only be opened when they have been disconnected from the voltage source or mains.
- All connecting cables of the electronic devices must be checked for damage regularly and must be exchanged if damaged.
- Absolutely comply to the regular inspections required by law according to VDE 0701 and 0702 for line-operated devices.
- Tools must not be used near or directly at concealed or visible power lines and conductor paths and also not at and in devices using external voltage – especially mains voltage - as long as the power supply voltage has not been turned off and all capacitors have been discharged. Electrolytic capacitors can be still charged for a long time after turning off.
- When using components, modules, devices or circuits and equipment the threshold values of voltage, current and power consumption specified in the technical data must absolutely be complied to. Exceeding these threshold values (even if only briefly) can lead to significant damage.
- The devices, components or circuits described in this manual are only adapted for the specified usage. If you are not sure about the purpose of the product, please ask your specialized dealer.
- The installation and setup have to be carried out by professional personnel.

## **Factory returning of old equipment**

According to German law concerning electronic devices old devices cannot be disposed off as regular waste. Our devices are classified for commercial use only. According to § 11 of our general terms of payment and delivery, as of November 2005, the purchasers or users are obliged to return old equipment produced by us free of cost. FunkTronic GmbH will dispose of this old equipment at its own expense according to regulations.

Please send old equipment for disposal to:

**FunkTronic GmbH  
Breitwiesenstraße 4  
36381 Schlüchtern**

**>>> Important hint:** freight forward deliveries cannot be accepted by us.

February 2<sup>nd</sup>, 2006

**Subject to change, Errors excepted**

## Terms and abbreviations

iLine 2-wire cable  
Radio 2-way-radio

$Z_R$  Reference impedance,  
this is the same as a real 2-wire-cable according to German TBR 15

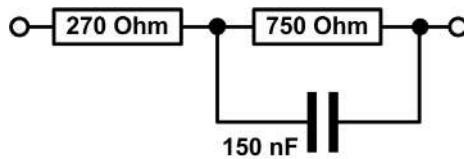

2D 2 wire  
4D 4 wire  
 $Z_r$  Complex impedance according to German TBR  
600 Real impedance 600 Ohm according to German TBR  
AC Remote control via AC voltage  
DC Remote control via DC voltage  
IN Input  
OUT Output  
I/O In- and output  
SDA I2C-Bus Data  
SCL I2C-Bus Clock  
TXD RS232 Transmitter  
RXD RS232 Receiver  
PTT Push To Talk  
DSP Digital Signal Processor  
FT FunkTronic

# Revision remarks

Modifications made are only mentioned in note form in this section. For detailed information please read the corresponding chapters.

- 06.02.2014 - translation to English version
- 02.01.2024 - correction of output level 2-wire
- 02.02.2024 - change of 19" version from 7TE to 10TE